

RAVAS ProLine 6200

Pallet truck scale with programmable scale functions



BENEFITS

- Superb accuracy
- Rotating RVS indicator
- 5" colour TFT display
- Programmable scale functions
- RS232, RS485, 4-20 mA or 0-10V output optional
- High capacity 14.8V / 5Ah Li-ion battery pack
- For parts counting and special applications

The hi-tech standard
Extremely accurate



RAVAS

FUNCTIONS

- Automatic and manual zero correction
- Gross/net weighing
- Automatic and manual tare through numeric keypad
- Entry of alphanumeric codes (max. 10 characters)
- Internal memory for 9 pre-set tare values
- Totalling
- Piece counting by sampling or calculation of piece weights
- Functions through parameters (on demand):
 - different print layout
 - different basic functionality (e.g. dosing)
- Error messages in display
- Printer power supply is switched on and of by the indicator
- Internal clock for date and time

STANDARD SPECIFICATIONS

- Weighing capacity 2.000 kg
- Graduation multirange:
 - 0 - 200 kg: graduation 0,1 kg
 - 200 - 400 kg: graduation 0,2 kg
 - 400 - 2.000 kg: graduation 0,5 kg
- Max. tolerance 0.08% of the load lifted
- Display TFT, 5" colour
- Foil keypad 20 keys
- Protection class load cells IP67, indicator IP69
- Power consumption 240 mA
- Battery 14,8Vdc / 5Ah, exchangeable; Li-ion battery pack, charger included
- Battery life 25 hours (depending on work and environmental conditions)
- Charger 230V/14,8Vdc - 1A
- Charging time approx. 6 hours
- Steering wheels rubber
- Loading wheels polyurethane, tandem
- Colour red (RAL 3000), epoxy painted
- Own weight 180 kg
- Pump with ergonomic lift

DIMENSIONS IN MM

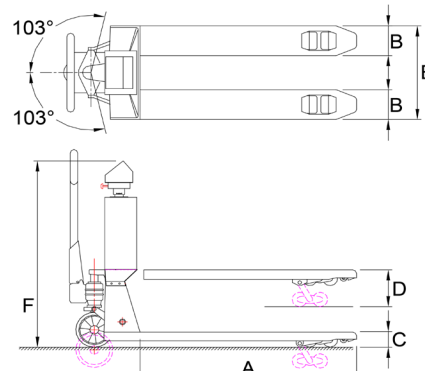

	Standard Chassis	Stainless Steel
A Fork length	1150	1150
B Fork width	160	160
C Minimum fork height	90	90
Minimum clearance	22	22
D Maximum fork height	200	205
Lifting height	110	120
E Width over forks	550	550
F Height to top indicator	1305	1305

Loading wheels

- type: PU tandem yes no
- type: Nylon tandem no yes

Steering wheels

- type: rubber yes no
- type: nylon no yes



Management System
 ISO 9001:2015
 ISO 14001:2015
 ISO 45001:2018
 www.tuv.com
 ID 0000037200

OPTIONS*

- Client specific software (see ProLine Touch)
- Extra exchangeable Li-ion battery pack
- Built-in thermal printer
- Data transfer to devices that have WiFi or Bluetooth® technology
- Legal for trade version, OIML III
- Premium quality stainless steel pallet truck

RAVAS Europe B.V.

Veilingweg 17, 5301 KM Zaltbommel, The Netherlands

T: +31 418 515220 E: salesoffice@ravas.com

WWW.RAVAS.COM

