

DTW

Operative Manual



INDEX

1. GENERAL INFORMATION	3
2. CAUTIONS AND GENERAL NORMS	4
3. DESCRIPTION AND INTENDED USE	5
4. MARKING OF “DTW” WEIGHBRIDGES	5
4.1 TECHNICAL AND METROLOGICAL MARKING OF “WEIGHING BARS”	5
4.2 POSITION MARKING.....	10
5. TECHNICAL SPECIFICATIONS AND DIMENSIONS OF THE WEIGHING SYSTEM	12
5.1 MAIN COMPONENTS	12
5.2 OVERALL DIMENSIONS	13
6. TRANSPORT	15
7. EARTHING OF THE SYSTEM	17
8. INSTALLATION ON THE FLOOR	21
DECLARATION OF CONFORMITY	22
WARRANTY	22

1. GENERAL INFORMATION

The purpose of this manual is to inform the user about all the requirements and the basic criteria for the installation, the use and the proper maintenance of the system purchased.

The “DTW” are innovative “dual track” weighbridges, with remarkably reduced height and weight: this allows an immediate and simple execution of operations such as transportation and installation.

Designed and built with very high-quality materials, the “DTW” weighbridges represent an efficient solution in terms of saving of money, operating space and time.

Suitable for weighing of vehicles of any category, and adaptable to any kind of application, the “DTW” weighing modules are weighing systems which can be used in places such as modern industries, farms, work yards, landfills, ports etc... and where it is necessary to change the logistic stations.

In relation to the kinds of vehicles to be weighed and to their expected use, it is possible to choose the weighbridge model according to the different capacities and dimensions available, which are (in tons); 15t, 30t, 60t, 80t.

This manual considers all the various types.

2. CAUTIONS AND GENERAL NORMS

- It is strictly FORBIDDEN for unauthorised personnel to access the work zone.
- In case of failure of components or accessories of the system, use only original spare parts.
- All the connections of the system must be carried out in compliance with the norms applicable in the installation zone and environment.
- If any anomalies are noticed whilst using the “DTW” weighbridge, stop working IMMEDIATELY and do not use the instrument until it has been specifically inspected and tested by specialised and authorised personnel or by personnel of the service department of Dini Argeo.
- It is strictly FORBIDDEN to load vehicles or other loads that exceed the nominal capacity of the system on the platform.
- All the weighing phases must be carried out positioning the load properly on the weighbridge.
- Avoid sharp accelerations or brakings when getting on and off the platform with the vehicle, or when positioning it.
- Loads without wheels (loose material, containers etc...) must be weighed avoiding their collisions or falling to the platform. Moreover, it is FORBIDDEN to trail or tug these loads on the platform.
- Do not weld, drill or modify the structure in any part without consulting the vendor. Possible damages or tampering annul the warranty conditions.
- Do not install the platform cables near to electrically conductive cables of medium and/or high tension. This may cause disturbances to the weight visualization. It is advisable to arrange a protected line just for the platform cables.
- Do not stand on, squash or expose to heat any of the shielded connection cables of the system.
- In the elevated versions, the weighbridge must be equipped with suitable side protections (guard rail, gangways etc...) in order to guarantee people safety and to provide a useful help to the driver, in case of transverse positioning or transit of the vehicle on the weighing system. These operations must not interfere with the weighing structure.
- Do not apply any kind of stress – apart from compression – on the weighing bars and on all the system components.
- Make sure that no weighing bar is partially or totally lifted during the weighing phase.
- Do not let material or corrosive liquids drop on the weighing unit.
- The installation workplace of the system must enable the protection of the connection cable between the modules and the indicator, via metal raceways built into the floor.
- The use of the system outside the temperature range $-10\text{ }^{\circ}\text{C} / + 40\text{ }^{\circ}\text{C}$ is NOT allowed.
- Flat and levelled surface.
- Moderate humidity and temperature (do not place near to heat sources).
- Do NOT use solvents or industrial chemical products to clean the system. Use just a damp cloth or normal cleaning products.
- Observe the safety measures established by the manufacturer of the weighing system and the legal standards applied in the country in which the system is used.
- The “DTW” weighbridge must be used exclusively as a weighing system. Any improper use, or different from the ones stated in this manual will relieve the manufacturer from all forms of liability with regard to personal injuries or material damages.

3. DESCRIPTION AND INTENDED USE

The weightbridges can be installed:

- At the same level of the road surface;
- On the road surface (elevated);
- On a metallic frame (elevated);
- Embedded in pre-existing groundwork.

Formed by pairs of modules designed to bear any load according to the parameters laid down in the directive 96/53/EEC (maximum load on a single axle for the vehicles transiting in Europe), the weighbridges “DTW” are built for excellent performances in any environmental condition. They are protected against STATIC overload of more than 200% of the platform nominal capacity.

The measuring element consists of a weight detection system through oscillating load bars (patented system) with integrated brake / acceleration compensating limits, that allow to obtain precise results during the weighing phase.

Each bar is made of 2 stainless steel load cells (IP68 norm), in compliance to OIML R60; they are also fitted with anti-slip rubber resting plates. Consequently, the system installation can be carried out even without fastening the bars to the floor by bolts.



Lastly, the “DTW” weighbridges can be connected to a Dini Argeo weight indicator, both in the “single scale” and “multirange” version.

4. MARKING OF “DTW” WEIGHBRIDGES

4.1 TECHNICAL AND METROLOGICAL MARKING OF “WEIGHING BARS”

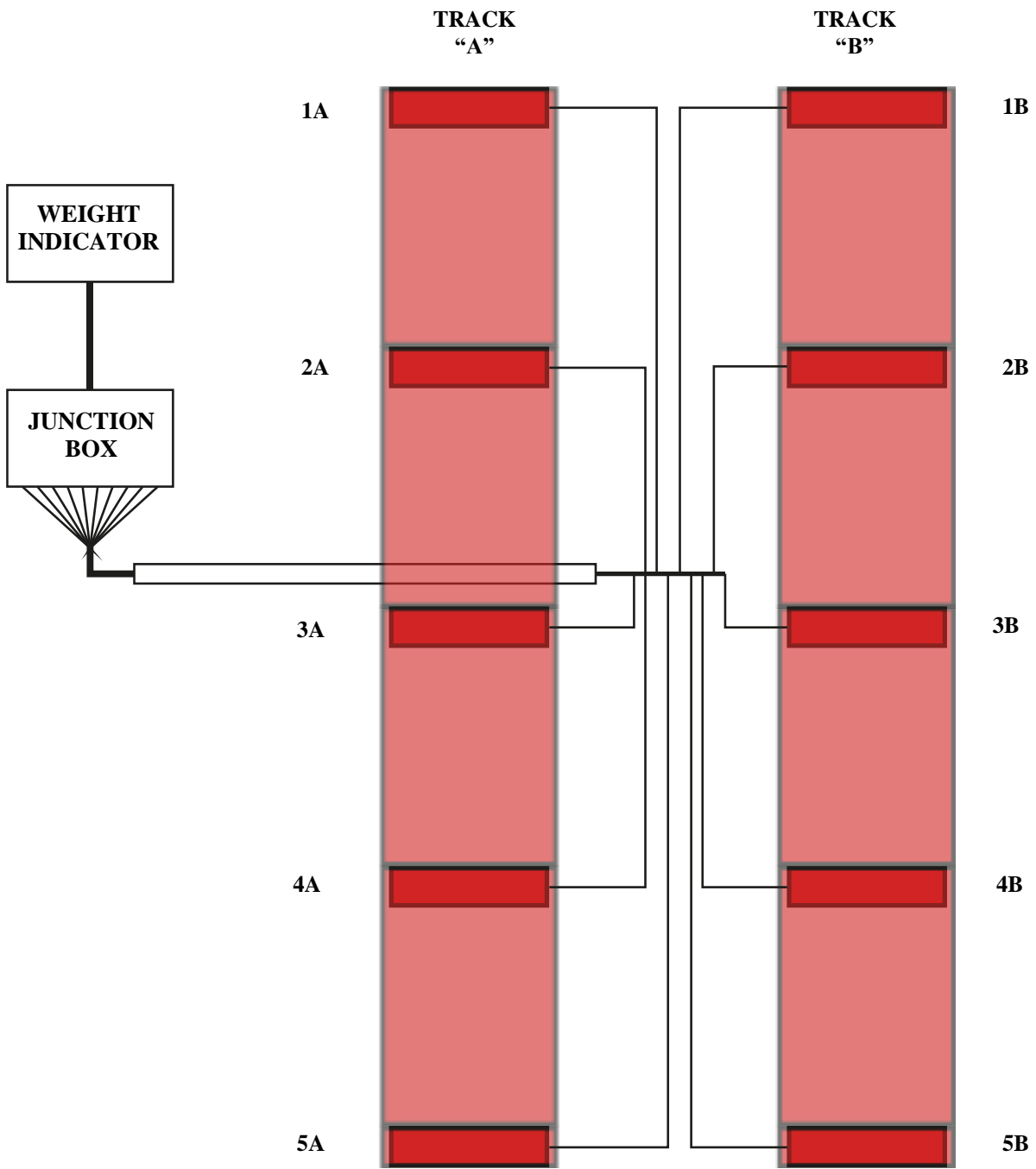
In relation to the use allowed, the “DTW” weighbridges are fitted with specific labels on all the weighing bars, in order to show the technical and metrological information of the system. For instance, in a system with 8 modules (bridges) and 10 weighing bars, each weighing bar will have the following marking:



<p style="text-align: center;">LABEL OF WEIGHING BAR "1A"</p> <p>Mod. DTWXXXXA-6 Max 60000 kg sn XXXXXXXXB1A 20 LOAD CELLS: XXXX-8000 WIRING CODE: EXCT. + Brown EXCT. – Gray SIGN. + Pink  SENS. + Green SENS. – White SIGN. - Yellow GND \perp Shield Made in Italy</p> <p>Load receiver sn. XXXXXXXXB1A Connected to Load receiver sn. XXXXXXXXB1</p>	<p style="text-align: center;">LABEL OF WEIGHING BAR "1B"</p> <p>Mod. DTWXXXXA-6 Max 60000 kg sn XXXXXXXXB1B 20 LOAD CELLS: XXXX-8000 WIRING CODE: EXCT. + Brown EXCT. – Gray SIGN. + Pink  SENS. + Green SENS. – White SIGN. - Yellow GND \perp Shield Made in Italy</p> <p>Load receiver sn. XXXXXXXXB1A Connected to Load receiver sn. XXXXXXXXB1</p>
<p style="text-align: center;">LABEL OF WEIGHING BAR "2A"</p> <p>Mod. DTWXXXXA-6 Max 60000 kg sn XXXXXXXXB2A 20 LOAD CELLS: XXXX-8000 WIRING CODE: EXCT. + Brown EXCT. – Gray SIGN. + Pink  SENS. + Green SENS. – White SIGN. - Yellow GND \perp Shield Made in Italy</p> <p>Load receiver sn. XXXXXXXXB2A Connected to Load receiver sn. XXXXXXXXB1</p>	<p style="text-align: center;">LABEL OF WEIGHING BAR "2B"</p> <p>Mod. DTWXXXXA-6 Max 60000 kg sn XXXXXXXXB2B 20 LOAD CELLS: XXXX-8000 WIRING CODE: EXCT. + Brown EXCT. – Gray SIGN. + Pink  SENS. + Green SENS. – White SIGN. - Yellow GND \perp Shield Made in Italy</p> <p>Load receiver sn. XXXXXXXXB2B Connected to Load receiver sn. XXXXXXXXB1</p>
<p style="text-align: center;">LABEL OF WEIGHING BAR "3A"</p> <p>Mod. DTWXXXXA-6 Max 60000 kg sn XXXXXXXXB3A 20 LOAD CELLS: XXXX-8000 WIRING CODE: EXCT. + Brown EXCT. – Gray SIGN. + Pink  SENS. + Green SENS. – White SIGN. - Yellow GND \perp Shield Made in Italy</p> <p>Load receiver sn. XXXXXXXXB3A Connected to Load receiver sn. XXXXXXXXB1</p>	<p style="text-align: center;">LABEL OF WEIGHING BAR "3B"</p> <p>Mod. DTWXXXXA-6 Max 60000 kg sn XXXXXXXXB3B 20 LOAD CELLS: XXXX-8000 WIRING CODE: EXCT. + Brown EXCT. – Gray SIGN. + Pink  SENS. + Green SENS. – White SIGN. - Yellow GND \perp Shield Made in Italy</p> <p>Load receiver sn. XXXXXXXXB3B Connected to Load receiver sn. XXXXXXXXB1</p>
<p style="text-align: center;">LABEL OF WEIGHING BAR "4A"</p> <p>Mod. DTWXXXXA-6 Max 60000 kg sn XXXXXXXXB4A 20 LOAD CELLS: XXXX-8000 WIRING CODE: EXCT. + Brown EXCT. – Gray SIGN. + Pink  SENS. + Green SENS. – White SIGN. - Yellow GND \perp Shield Made in Italy</p> <p>Load receiver sn. XXXXXXXXB4A Connected to Load receiver sn. XXXXXXXXB1</p>	<p style="text-align: center;">LABEL OF WEIGHING BAR "4B"</p> <p>Mod. DTWXXXXA-6 Max 60000 kg sn XXXXXXXXB4B 20 LOAD CELLS: XXXX-8000 WIRING CODE: EXCT. + Brown EXCT. – Gray SIGN. + Pink  SENS. + Green SENS. – White SIGN. - Yellow GND \perp Shield Made in Italy</p> <p>Load receiver sn. XXXXXXXXB4B Connected to Load receiver sn. XXXXXXXXB1</p>

LABEL OF WEIGHING BAR "5A"	LABEL OF WEIGHING BAR "5B"
<p>Mod. DTWXXXXA-6 Max 60000 kg sn XXXXXXXXB5A 20 LOAD CELLS: XXXX-8000 WIRING CODE: EXCT. + Brown EXCT. – Gray SIGN. + Pink SENS. + Green SENS. – White SIGN. - Yellow GND \perp Shield Made in Italy</p>	<p>Mod. DTWXXXXA-6 Max 60000 kg sn XXXXXXXXB5B 20 LOAD CELLS: XXXX-8000 WIRING CODE: EXCT. + Brown EXCT. – Gray SIGN. + Pink SENS. + Green SENS. – White SIGN. - Yellow GND \perp Shield Made in Italy</p>
<p>Load receiver sn. XXXXXXXXB5A Connected to Load receiver sn. XXXXXXXXB1</p>	<p>Load receiver sn. XXXXXXXXB5B Connected to Load receiver sn. XXXXXXXXB1</p>

To better explain the interpretation of these labels, here is the meaning of each piece of information written.

Labels on the weighing bars of the track:

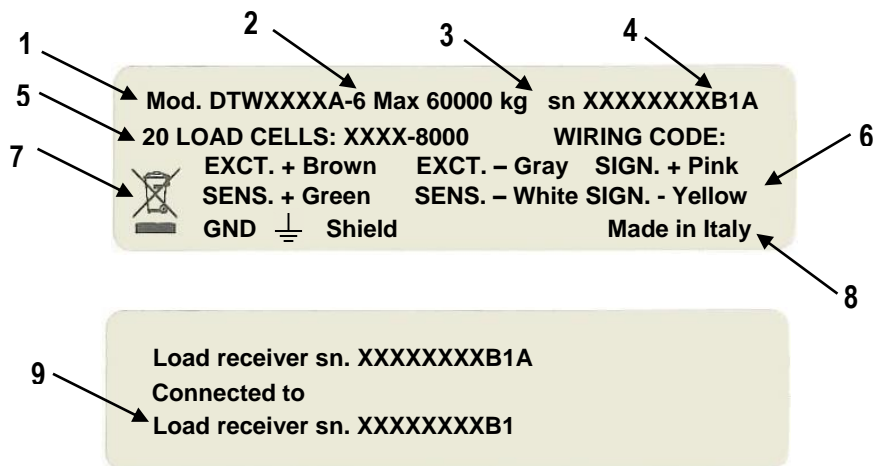

1. Model of the weigh bridge.
2. Maximum capacity or full scale of the system.
3. Serial number of the weighing bar.
4. Identification of the weighing bar (number of the bar and track on which it is installed).
5. Number of the cells in the system, identified by model and maximum capacity (each).
6. Colours of the cell cables and related signal.
7. Symbol of the dustbin: it means that when the product reaches the end of its useful lifetime, it must be handed over to the authorized waste recycling centres.
8. Country in which the system is manufactured.
9. Model and serial number of the junction box to which the weighing bar is connected.

Labels on the junction box:

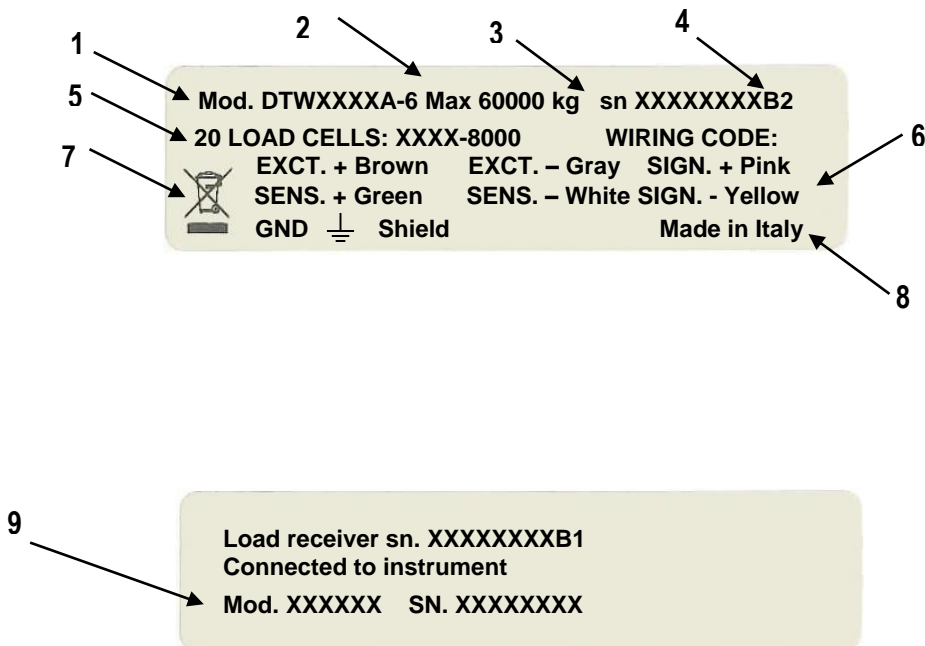

1. Model of the weigh bridge.
2. Maximum capacity or full scale of the system.
3. Serial Number of the junction box.
4. Identification of the junction box.
5. Number of cells in the system, identified by model and maximum capacity (each).
6. Colours of the cell cables and related signal.
7. Symbol of the dustbin: it means that when the product reaches the end of its useful lifetime, it must be handed over to the authorized waste recycling centres.
8. Country in which the system is manufactured.
9. Serial Number of the indicator to which the junctions box is connected.

If the “DTW” weighbridge is approved and, consequently, suitable for use in commercial transactions, the system will be fitted with specific approval seal.

NOTE: the seals and legal stamps on the components of the system must not be modified or removed for any reason whatsoever. In case of tampering or removing of this information the system’s warranty is annulled and the manufacturer is relieved from all feasible direct or indirect personal injuries or material damages that may occur.

THE PLATES ARE ADHESIVE AND THEY WILL BE DESTROYED ONCE DETACHED.

4.2 POSITION MARKING

Beyond the technical and metrological marking, the system is fitted with specific labels on each weighing bar, in order to identify its position inside the system itself.

For example, in a weighbridge with 8 modules (bridges) and 10 weighing bars, the marking will be the following:

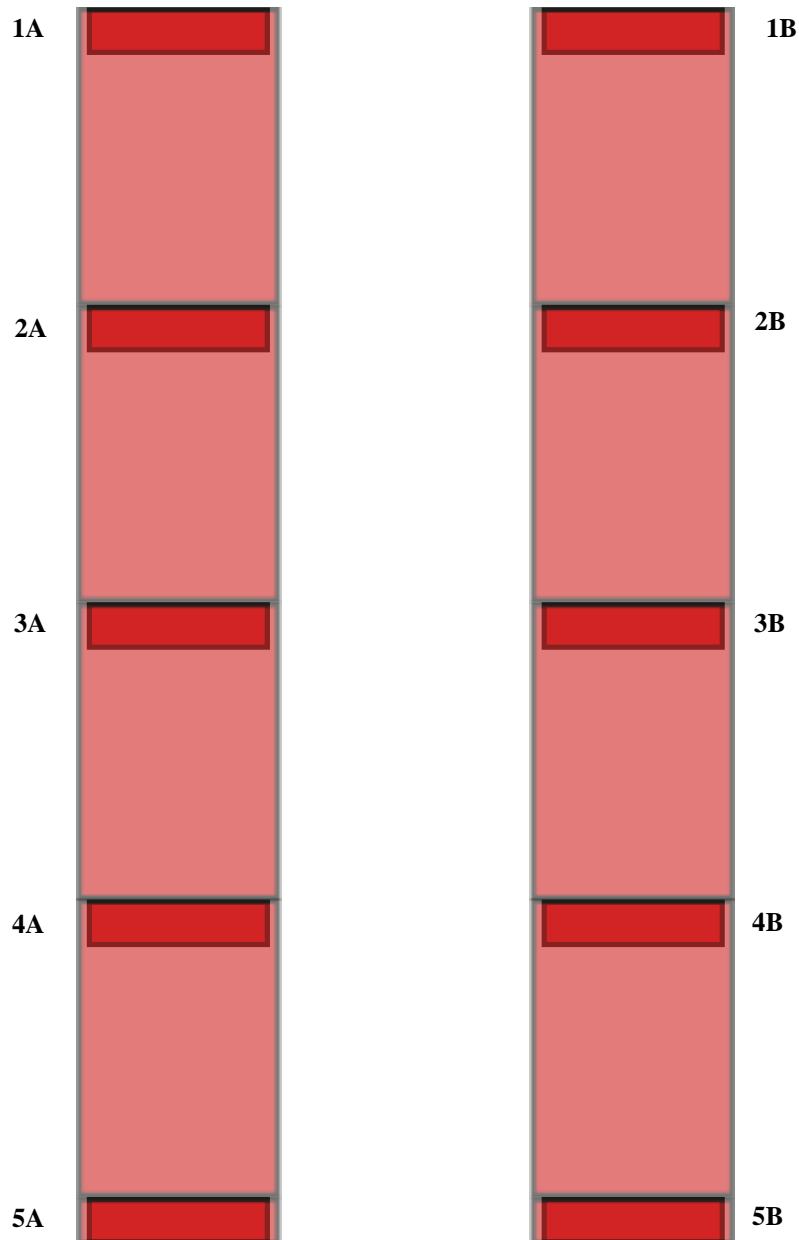

As it can be noticed from the previous image, each weighing bar is fitted with the related labels regarding its position inside the system. These labels are designed to make the installation simple and immediate. The bars and the platforms must be positioned with the labels on their internal side. In the next paragraph more details about these labels are added.

POSITIONING LABEL ON THE WEIGHING BARS

The following label indicates:

- The number “**1**”, which is the number of the weighing bar.
- The letter “**A**”, that identifies the track in which the weighing bar must be positioned.

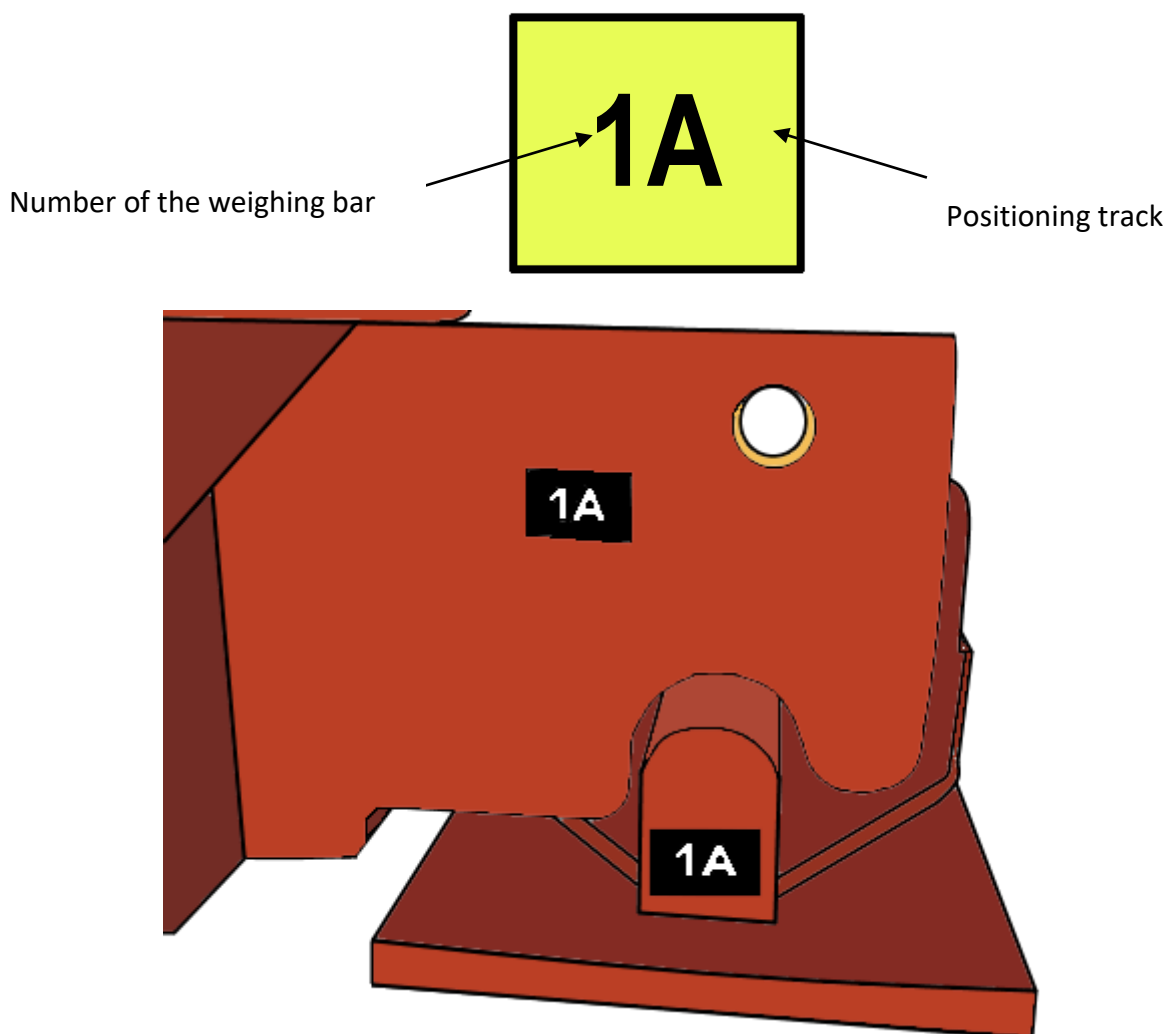

5. TECHNICAL SPECIFICATIONS AND DIMENSIONS OF THE WEIGHING SYSTEM

5.1 MAIN COMPONENTS

In the following illustration there is a list of the main parts of the “DTW” weighbridge.

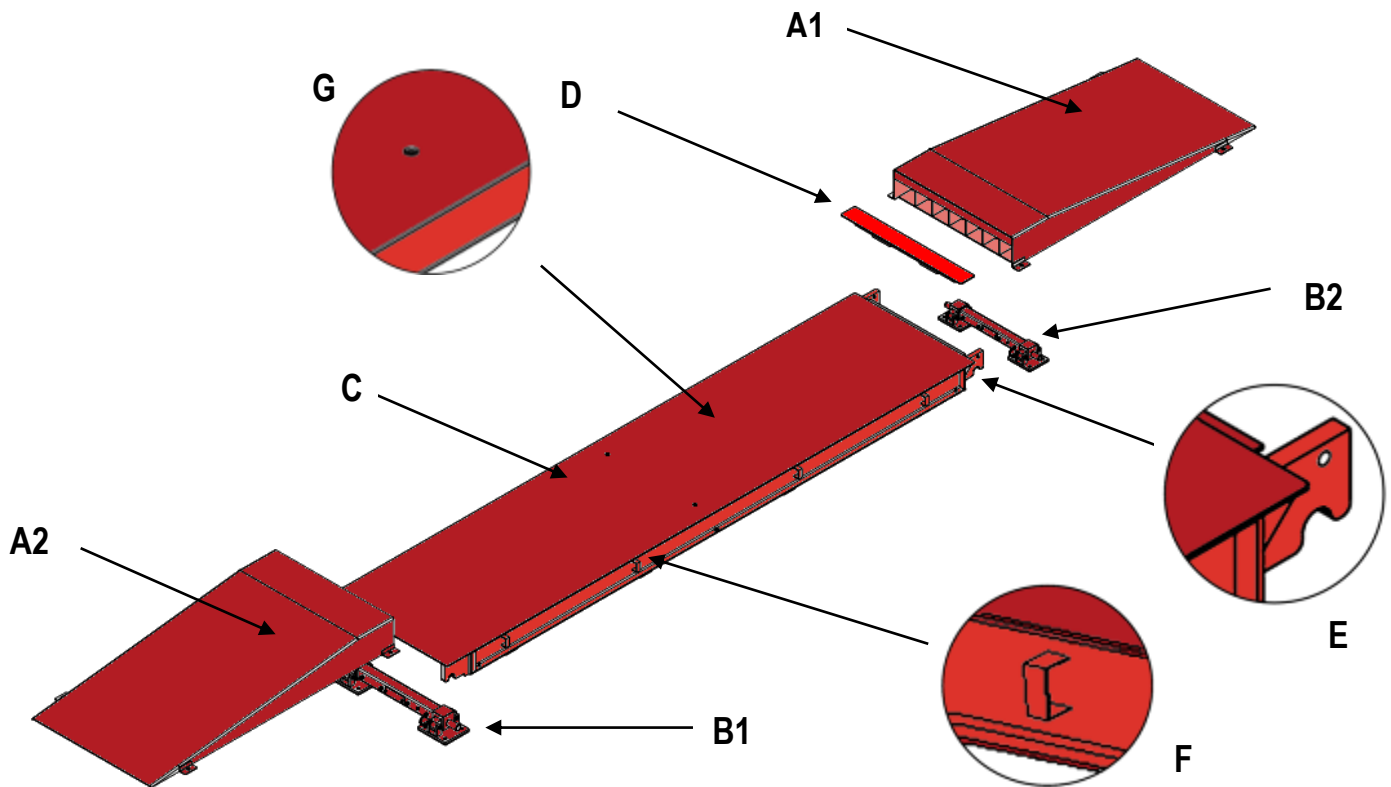

- **A1,A2:** metal ramps to get on and off the bridge (optional).
- **B1, B2:** weighing bars (for weight detection).
- **C:** weighing module (bridge platform).
- **D:** inspection cover of the support plates of the weighing module.
- **E:** support plate of the weighing module.
- **F:** side hook for cable management.
- **G:** threaded hole for lifting/handling the weighing module using “eyebolts”.

NOTE: since the “DTW” is an approved weighing system, spare parts are not supplied directly to the end users. The replacement of the system components will be done only by qualified personnel of the manufacturer during the maintenance operations.

5.2 OVERALL DIMENSIONS

The “DTW” weighbridge has, among its main features, the remarkably reduced dimensions. For more details, see the following drawings.

NOTE: all the dimensions are expressed in mm.

DIMENSIONS OF THE SINGLE WEIGHING MODULE (BRIDGE)

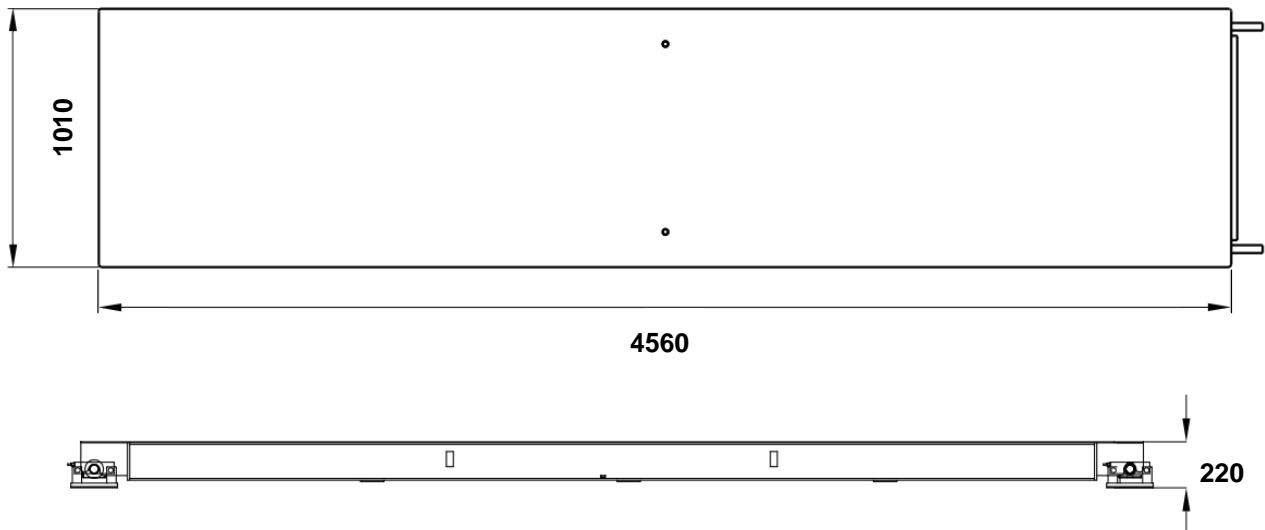

RAMP DIMENSIONS (OPTIONAL ACCESSORY)

Available ramps:

IC190-1: Kit of 4 painted steel ramps, with maximum load-bearing capacity of 30 t per pair, to be used directly on the road surface in mobile applications (for DTW with maximum load-bearing capacity of 30 t). Ramp dimensions: 1.40 x 1 x 0.22 m.

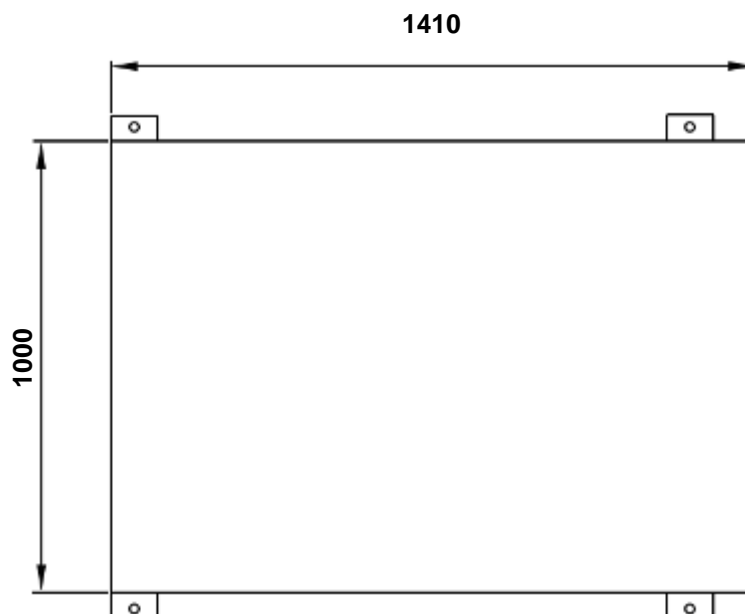

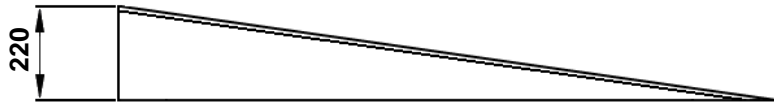

IC190R-1: 4 mobile ramps, made of 4 painted and reinforced framework filled with concrete. Maximum load-bearing capacity of 80t per pair. Ramp dimensions: 2.05x1x0.22 m. Fitted with elevated plates for platform.

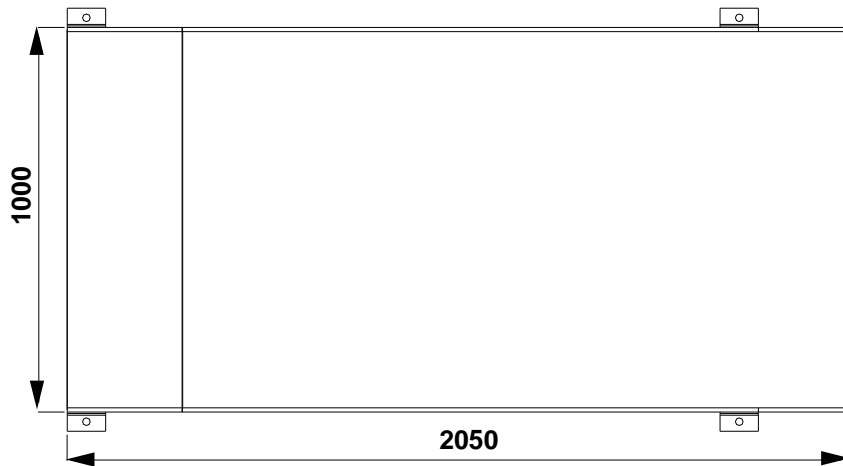

6. TRANSPORT

During the transport of the “DTW” weighbridge, it is necessary to avoid the compression of the system components (both on the top and on the sides) by possible external elements. Thus, do not superimpose materials with a weight higher than the platform's capacity, so as not to overload the system.

CORRECT position of the module (bridge) on the forklift truck during the handling procedures.

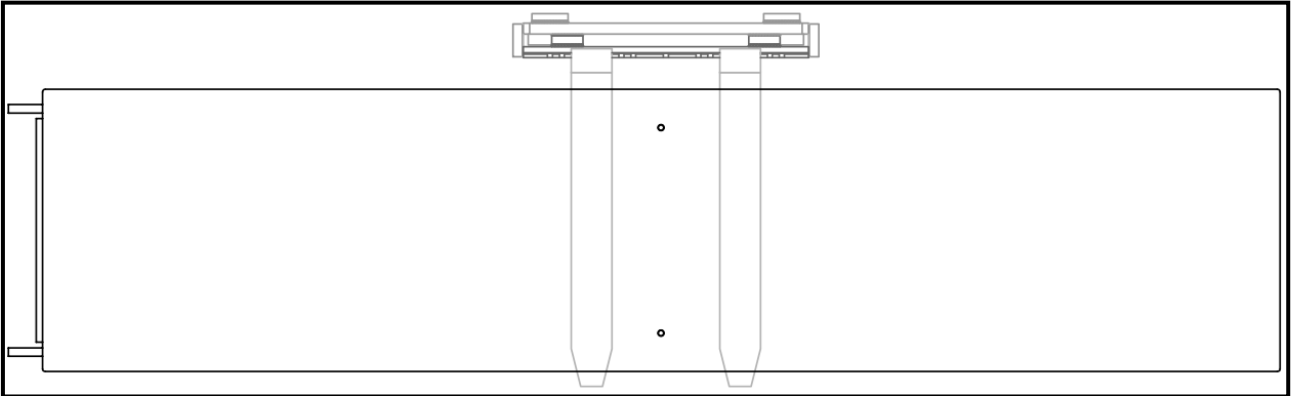

INCORRECT position of the module (bridge) on the forklift truck during the handling procedures.

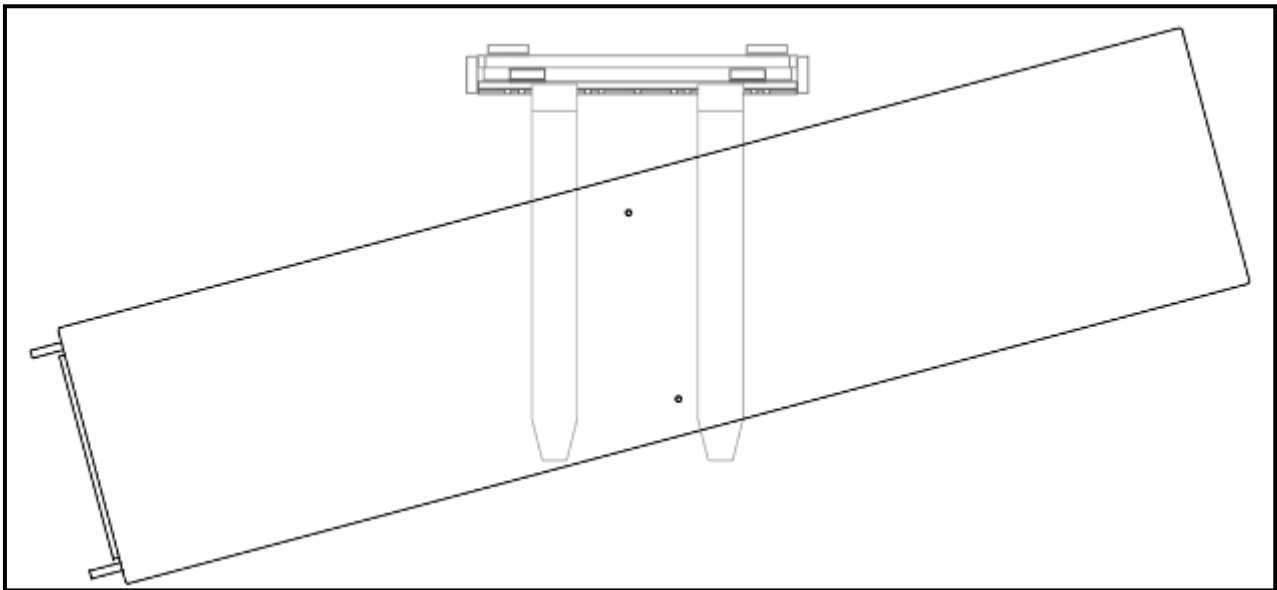

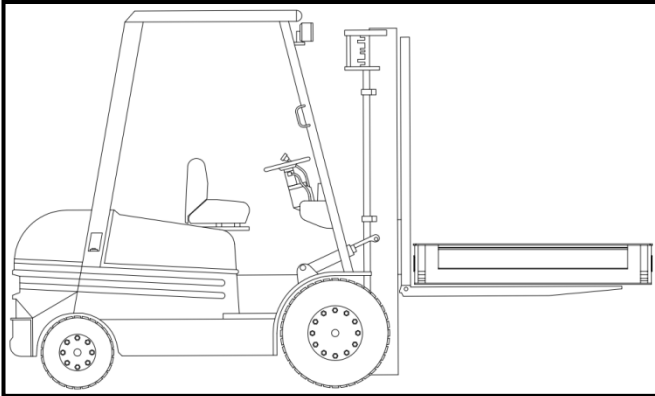

CORRECT position of the module (bridge) on the forklift truck during the handling procedures.

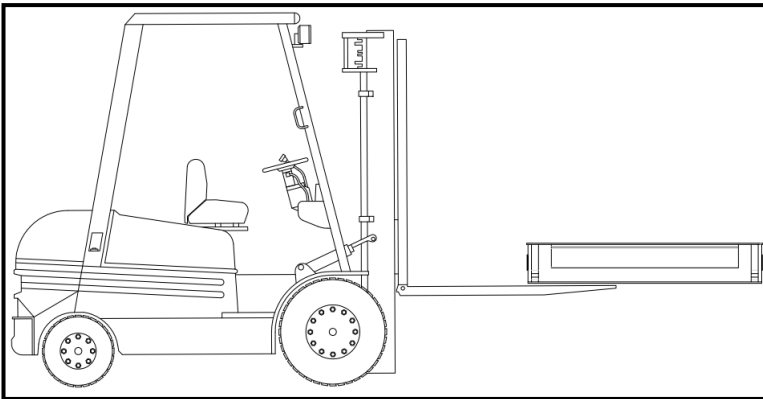

INCORRECT position of the module (bridge) on the forklift truck during the handling procedures.

7. EARTHING OF THE SYSTEM

To ground the system, the following material is provided:

- 4 copper cables, linked to each bar.
- 1 ground cable (25 mm²); length 650 mm for each weighing bridge.
- Bolts thread M8 and screws for fixing the weighing bars to the bridges.

GROUNDING OF EACH BAR

Every weighing bars has two earthing cables, one in every fixing plate, and they were used to connect to the same potential the weighing bar with previous and following bridges; see the image below of connection of a fixing plate with the bridge.

Connect both earth cables of the heading weighing bar to the same bridge.

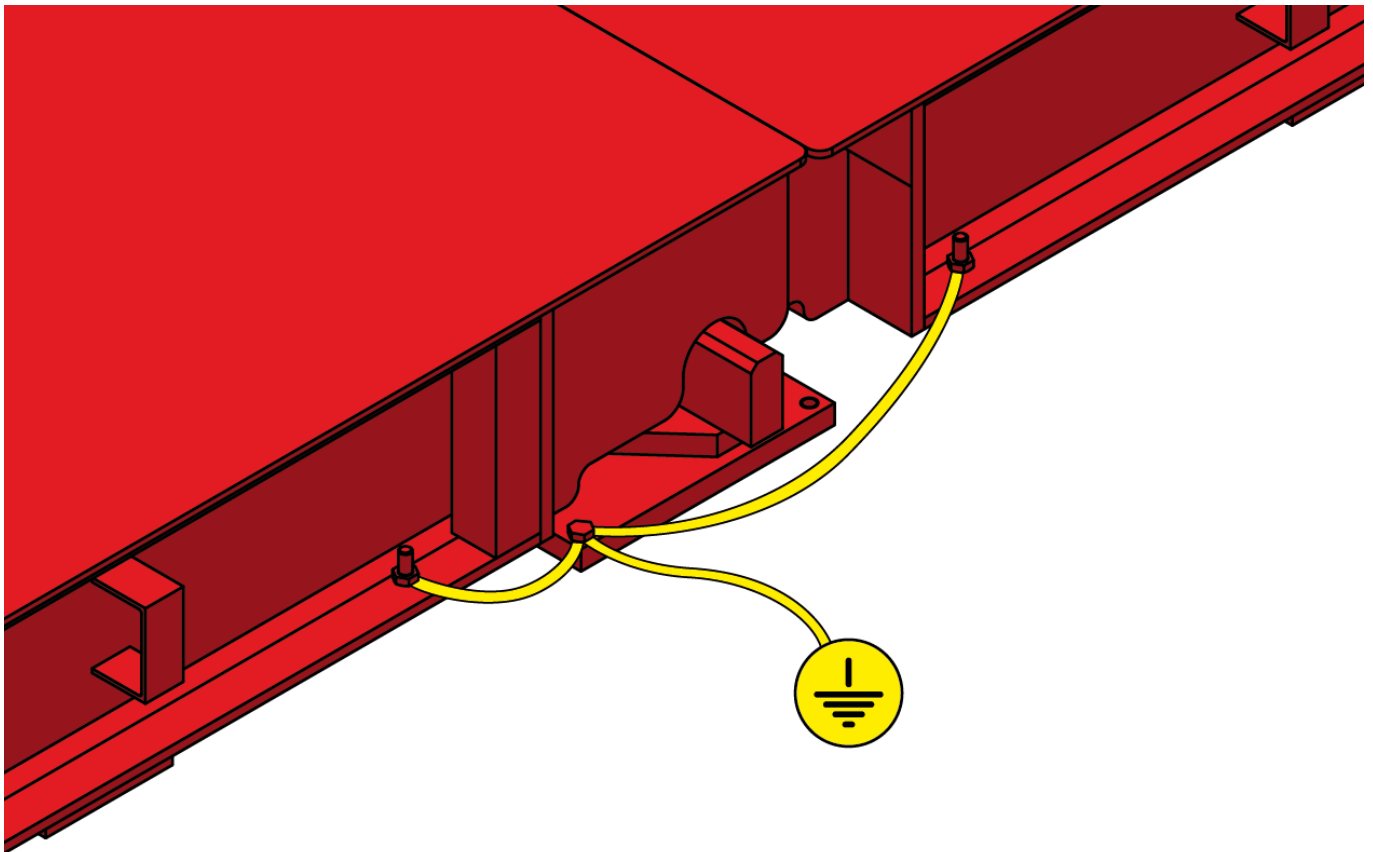

MOBILE PLATFORM ON THE FLOOR

After connecting the bars and the bridges through the wires present, the whole weighing system must be grounded using the ground wires of 25 mm² supplied on each bridge. Connect them to a point of common ground and brought to the earth electrodes (if present), or to your ground system (if present). Evaluate whether to create an earthing point for the indicator, to be connected to the respective point of common ground of the platforms.

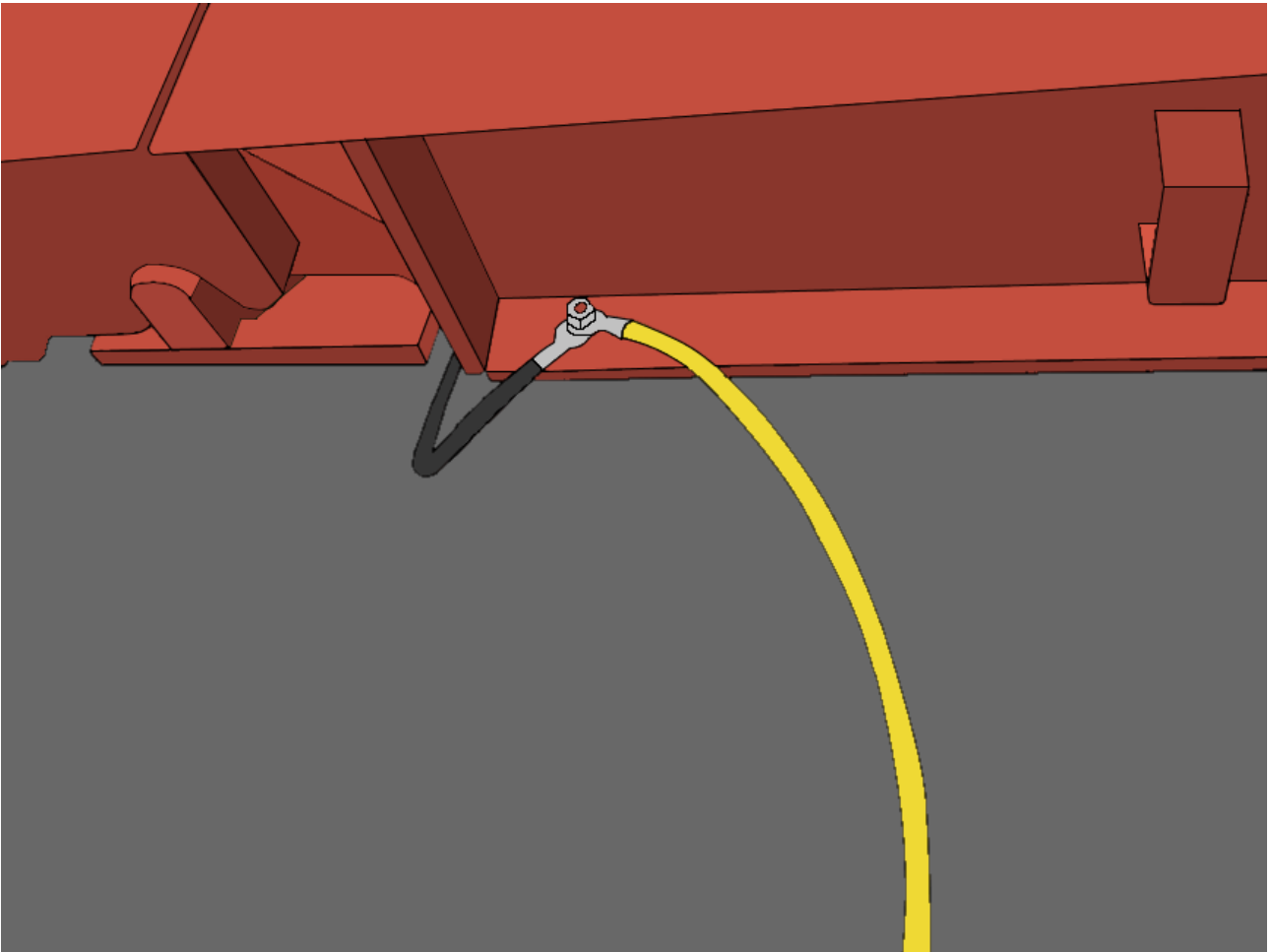

FIXED PLATFORM ABOVEGROUND AND UNDERGROUND

After having properly connected the copper wires present between the bars and the bridges, it is necessary to ground all the weighing bars (with ground wires on each bridge), through wells and canalizations placed subtrack in the base of the weighing system.

Connect all the wells with copper wires having section at least 50 mm². Through canalizations founded under the concrete bases, bring all the cables from the foundations to the earth electrodes dedicated exclusively to the weighing system.

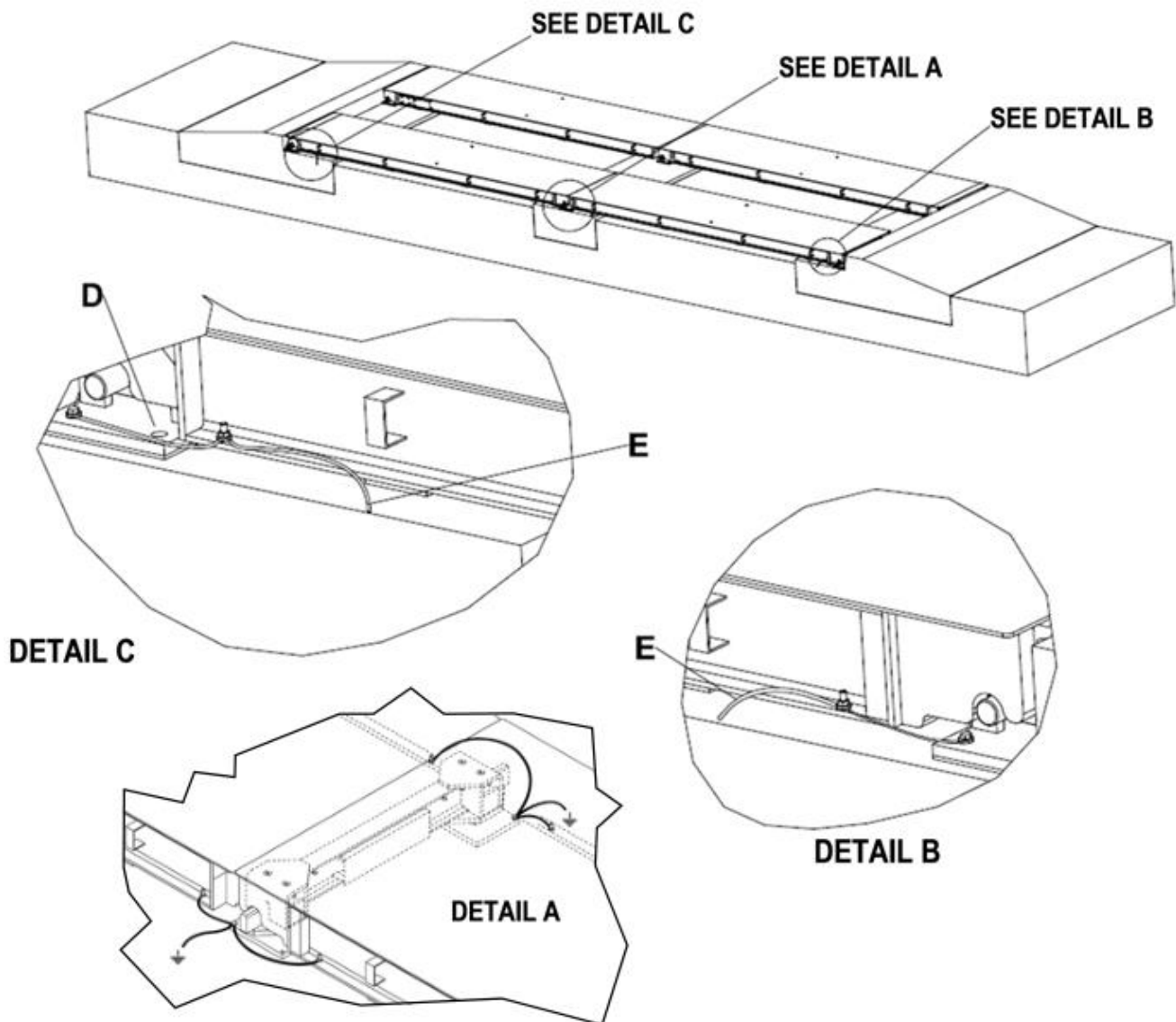

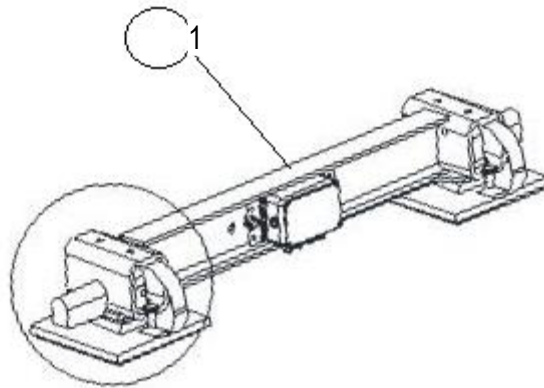

A, B, C, D - enlarged detail
D - connect all the bridges to the earthing network
E - earthing network

1 – Weighing bar

8. INSTALLATION ON THE FLOOR

For installations of weighbridges of variable length (from 4,5 to 18 metres).

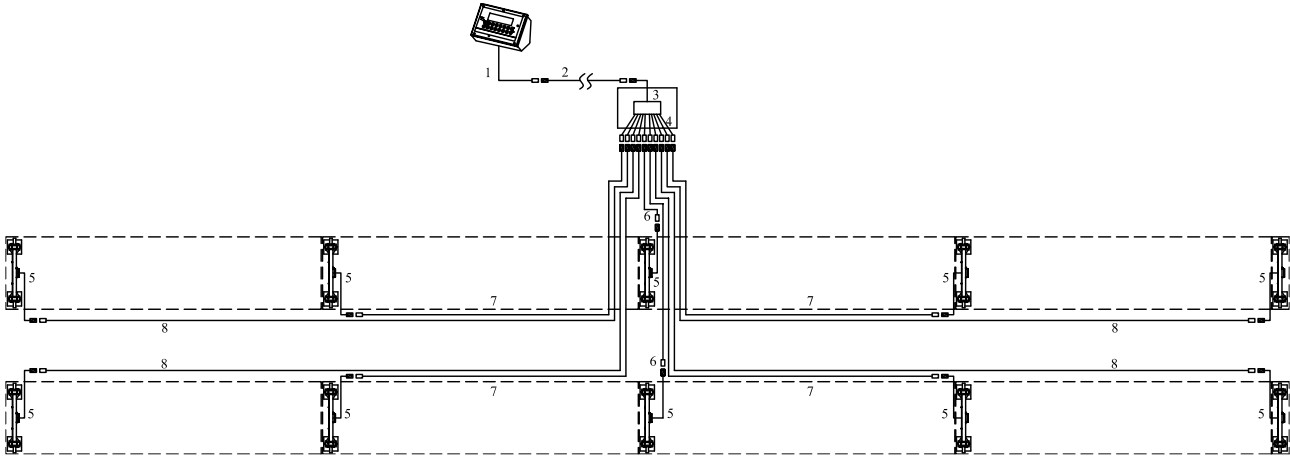

In case of platforms long 22,5 metres or more (starting from 12 weighing bars).

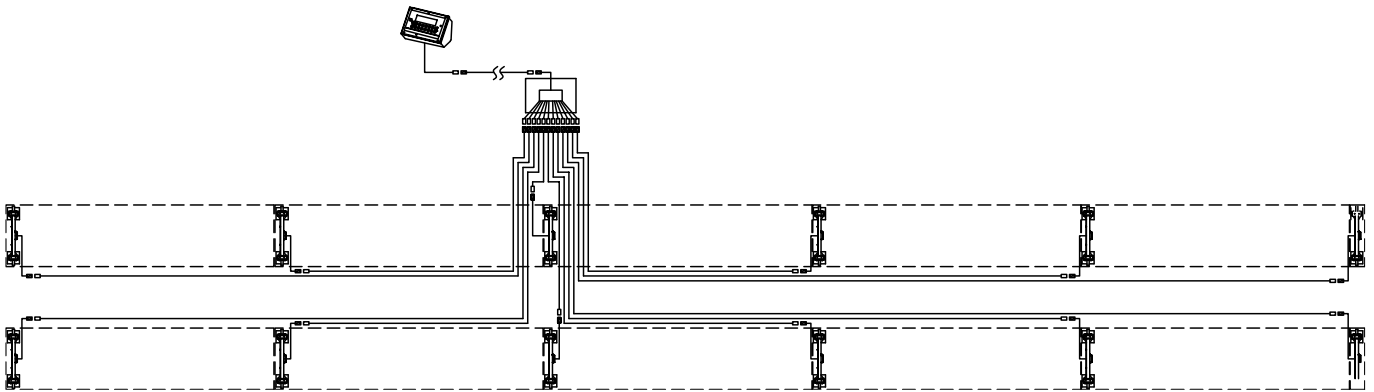

DECLARATION OF CONFORMITY

This device complies with the essential standards and other pertinent standards of applicable European regulations. The Declaration of Conformity is available on the Website www.diniargeo.com.

WARRANTY

The warranty is valid for TWO YEARS from date of consignment of the instrument and covers free of charge labour and spare parts for INSTRUMENTS RETURNED AT THE CUSTOMER'S CHARGE to the VENDOR'S PREMISES and for faults that are NOT attributable to the customer (for example, improper use) and that have NOT been caused during transport.

If, for any reason, the repair work is requested (or necessary) at the actual workplace, the customer will be charged for the transfer expenses of the technician: travelling time and expenses and possibly board and lodging.

If the instrument is consigned by courier, the transport expenses (there and back) will be charged to the customer.

The WARRANTY IS ANNULLED if the faults are due to unauthorised personnel using the weigh bridge or due to connection to equipment installed by others or due to the incorrect connection to the power supply mains.

Indemnity is EXCLUDED with regard to direct or indirect damages caused by the customer following failed or partial operation of the instruments or systems sold, even during the warranty period.

STAMP OF THE AUTHORISED SERVICE CENTRE

