

AXL

10 kg ... 75 kg

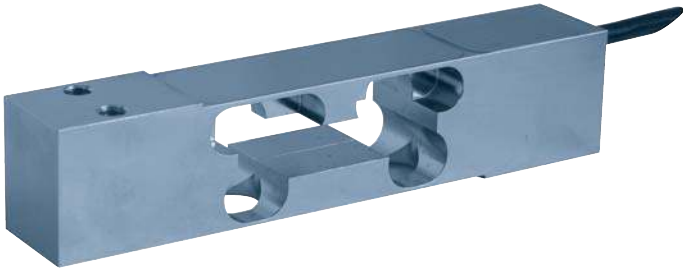

- Construction en acier inoxydable, soudé hermétiquement (IP68, IP69K)
 - Homologué jusqu'à 3 000 d OIML R60 (jusqu'à 50 kg)
 - Idéal pour balances monocapteur et doseuses pondérales, utilisées en environnement humide et corrosif
 - Excentration de charge compensée
 - Conception brevetée alliant haute précision et haute tenue environnementale
- *Stainless steel construction, hermetically welded (IP68, IP69K)*
 - *3 000 d OIML R60 approved (up to 50 kg)*
 - *Ideally suited for platform scales in humid and corrosive environments*
 - *Off-center load compensated*
 - *Patented design to combine high accuracy and high environmental protection level*

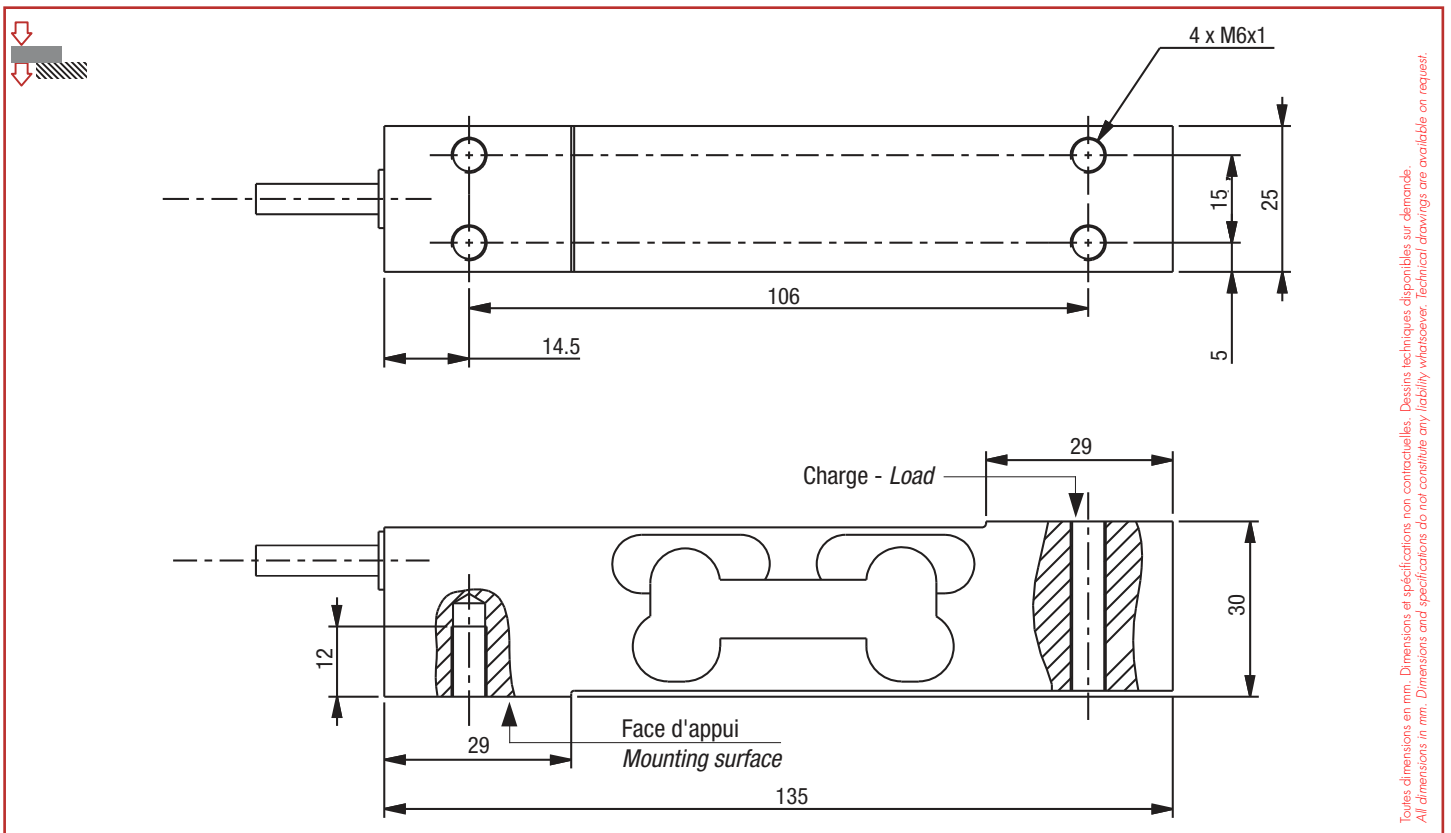

Câblage - Wiring

+ alim.	+ signal	- signal	- alim.	+ réf.	- réf.
+ excit.	+ signal	- signal	- excit.	+ sense	- sense
marron	jaune	blanc	vert	gris	rose
brown	yellow	white	green	grey	pink



Caractéristiques - Specifications

MÉTROLOGIQUES	METROLOGICAL	C3 5e	C3 10e/15e	
Capacité nominale (Cn)	Rated capacity (Cn)	10	15*, 20, 50, 75*	kg
Erreur combinée	Combined error	±0.017	±0.017	%Cn
Effet de la temp. sur le zéro	Temperature effect on zero	±0.0028	±0.0014/15e = ±0.0009	%Cn/°C
Effet de la temp. sur la sensibilité	Temperature effect on sensitivity	±0.0014	±0.0014	%Cn/°C
Fluage (30 min.)	Creep error (30 min.)	±0.025	±0.025	%Cn
Taille de plateau maximum	Maximum platform size	400 x 400	400 x 400	mm
MÉTROLOGIE LÉGALE OIML R60	LEGAL METROLOGY OIML R60			
Classe de précision	Accuracy class	C3	C3	
Capacité maximale (E _{max})	Maximum capacity (E _{max})	10	15*, 20, 50, 75*	kg
Nombre max. d'échelons (n _{max})	Max. number of LC intervals (n _{max})	3 000	3 000	d OIML
Échelon de vérification min. (v _{min})	Minimum verification interval (v _{min})	2	1*, 2, 5, 5*	g
Z=E _{max} /(2xDR)	Z=E _{max} /(2xDR)	3 000	3 000	
ÉLECTRIQUES	ELECTRICAL			
Plage de tension d'alimentation	Nominal range of excitation voltage		1 ... 15	V
Sensibilité nominale à C _n	Rated output at C _n		2 ±10 %	mV/V
Plage de zéro initial	Zero balance		±10	%C _n
Résistance d'entrée/sortie	Input/output resistance		385 ±20 / 350 ±5	Ω
Résistance d'isolement	Insulation resistance		5 000	MΩ/50V
GÉNÉRALES	GENERAL			
Plage de temp. compensée	Compensated temperature range		-10 ... +40	°C
Plage de temp. de fonctionnement	Service temperature range		-20 ... +60	°C
Charge limite admissible	Safe load limit		150	%E _{max}
Charge ultime avant rupture	Ultimate overload		200	%E _{max}
Couple de serrage	Tightening torque		15	Nm
Degré de protection	Protection class		IP68 / IP69K	EN60529/ISO20653
Matière	Material			
Corps d'épreuve	Measuring body		Acier inoxydable - Stainless steel	
Gaine de câble	Cable sheath		PVC	
Longueur du câble	Cable length		3	m
Poids net	Net weight		0.7	kg

* AXL C3 15e

Options - Options

ATEX 94/9/EC, IECEx

Ⓢ II 1 G/D, Ex ia IIC T6 Ga, Ex ia IIIC T80°C Da, IP6X, -20°C < Ta < +60°C (zone 0/20)

Ⓢ II 1 D, Ex ta IIIC T125°C Da, IP6X, -20°C < Ta < +60°C (zone 20)

Ⓢ II 3 G, Ex nA IIC T6 Gc, -20°C < Ta < +60°C (zone 2)

Accessoires - Accessories



SOLE UK DISTRIBUTOR
 Positive Weighing Solutions Ltd. Unit 8 The Clifton Centre, Spring Lane South Malvern. WR14 1BJ.
 01684 561002
 www.positiveweighing.co.uk
 sales@positiveweighing.co.uk

